

PART 1 – GENERAL

1.01 DESCRIPTION

- A. General
 - 1. Furnish Bi-Fold Electric (SST-IIe) System complete from one manufacturer. Provide all labor, materials, tools and equipment to furnish the Single-Swing System complete as herein specified.

1.02 RELATED WORK BY OTHERS

- A. Preparation of opening including jambs and header will be by General Contractor. Any deviation of site conditions contrary to approved shop drawings must be called to the attention of the architect.
- B. All header, blocking, support structures and jambs as required.
- C. Paint or otherwise finishing all trim and other materials adjoining door.

1.03 SUBMITTALS

- A. Product Data
 - 1. Submit manufacturer’s product data and roughing-in diagrams.
 - 2. Complete shop drawings are to be provided prior to fabrication indicating construction and installation details.

1.04 QUALITY ASSURANCE

- A. Provide each Bi-Fold Electric System as a complete unit by one manufacturer, including frames, panels, brackets, guides, hardware, operators and installation accessories to suit opening.
- B. Wind Loading: Manufacture each Bi-Fold Electric System to withstand 90 mph pressure. Higher pressure requirements may be considered on a project-by-project basis.
- C. Preparation of the opening shall conform to the criteria set forth by UBC, 2000 International Building Code & 1999 Standard Building Code (ASCE 7-98).

1.05 PRODUCT DELIVERY, STORAGE AND HANDLING

- A. Proper storage of the Single-Swing system before installation and continued protection during and after installation will be the responsibility of the general contractor.

1.06 WARRANTY

- A. Frame/Panel, electric actuators and controls shall be guaranteed for one year against defects in material and workmanship from date of shipment to the job site.
- B. Optional factory-supplied, manufacturers-standard glass retainer system and glass inserts shall be guaranteed for one year against defects in material and workmanship from date of shipment.
- C. Retainer system, glass inserts or other cladding/covering by others is not included in this warranty.

PART 2 – PRODUCTS

2.01 ACCEPTABLE MANUFACTURERS

- A. Subject to compliance with requirements, manufacturers offering products which may be incorporated into the work, include, but are not limited to, the following:

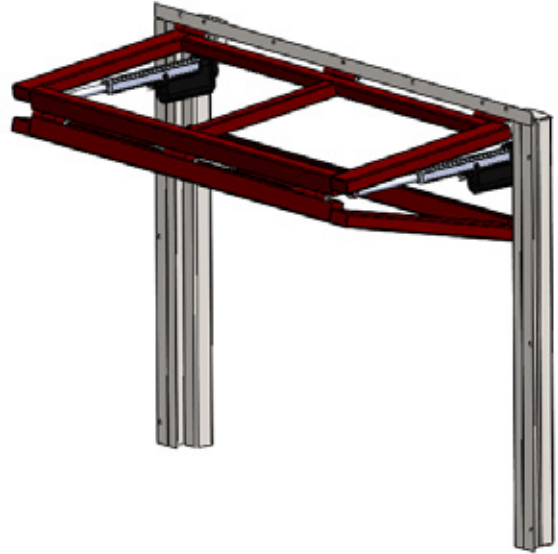

- P.O.Box 312, Sohar, Oman
Tel: + 968 2685 0261
Fax: + 968 2685 0258
Email: info@gibcaoman.com
Website: www.gibcaoman.com
 - B. Upon compliance with all of the criteria specified in this section, manufacturers wishing to bid products similar to the product specified must submit to the architect - 10 days prior to bidding - complete data in support of compliance. The submitting manufacturer guarantees the proposed substituted product complies with the product specified and as detailed on the drawings.
- 2.02 MATERIALS**
- A. Product to be Bi-Fold Electric (SST-IIe) System as furnished by Crown Doors, LLC (Crown)
 - 1. Construct panel/frame with structural steel tube (of ASTM-A500 grade minimum) framing to comply with applied wind code.
 - a. Optional: 304 stainless steel tube framing for highly corrosive environments.
 - 2. Frames shall be constructed of structural steel tubing and other structural steel shapes, and designed to the same loading requirements for live, dead and wind loads as the surrounding construction, with a maximum CTC from vertical and horizontal members of 60”.
 - 3. Panel frame shall be designed so that no center “cane bolt” is required in the floor.



SPECIFICATIONS: BI- FOLD ELECTRIC (SST-IIe) SYSTEM

4. Panel frame shall be factory-welded at all joints and connections, with smooth welds not to exceed 1/4" [6] thickness.
 5. System shall include factory-installed, steel "Inside-sash" (infill) glass retainer system (glazing stops) and glass inserts
 6. Panel frame and glazing stops shall be factory powder-coated any manufacturers' std. RAL color for finish and corrosion resistance.
 7. System shall included full-perimeter, factory-installed neoprene seals/weather stripping..
- B. Bi-Fold Electric System shall be operated by linear actuators that are mechanically fastened to the panel frame.
1. Actuators will be designed to carry the required loads during operation, open position and closed position.
 2. Speed: Approx. 30-40 sec. fully-closed to fully-open position.
- C. Power: Standard voltage is 120v, single phase, 10-amp.
1. "Up-Down" push button or key switch controls for separate mounting, by others.
 2. Control box to operate (2) linear actuators which open and close the door/window. Control box to be pre-wired, factory-tested and provided with supply cables for final hook-up (by others).
 3. "Open-Close" control units will be wired for constant-hold operation.
 4. Incoming electrical source to control box to be supplied by others.
 5. Each linear actuator shall have thermal overload protection for the motors.
- D. Finishes
1. Entire system frame and panel shall be cleaned and factory powder-coated any manufacturer's std. RAL color for finish and corrosion resistance..
 - a. Optional Finishes
 - i. Manufacturers' standard primer, prepared for field finishing, by others
- E. Available Accessories/Options
1. Photo eyes or lead-edge sensor that stops (or stops and reverses) the downward movement of the door/window.
 2. Warning horn/Strobe light assembly
 3. Remote receiver w/transmitter
 - a. Additional transmitters available
 4. 24v DC battery back-up system
 5. External, weather-resistant, "open-close" control wired for constant-hold
 6. Hurricane pins, side-mount
- 2.03 OPERATION
- A. The Bi-Fold Electric System shall be extended/retracted in the opening using a constant-hold push-button or key switch, operating linear actuators mounted to the door/window frame.

PART 3 - EXECUTION

3.01 SAFETY

- C. Photo eyes or lead-edge sensor optional.

3.02 INSTALLATION

- A. Installation of the Bi-Fold Electric System shall be by a contractor familiar with this type of installation and be in strict accordance with the approved build drawings and manufacturers standard printed specifications, instructions and recommendations. All moving parts will be left in good operating condition.
- B. Permanent or temporary electric wiring shall be brought to the control box location before installation. After the Bi-Fold Electric System is installed, the general contractor assumes the responsibility of any damage to the system or system components during construction until the building is turned over to the owner.

3.03 CLEANING

- A. All surfaces shall be wiped clean and free of handprints, grease and oil.

3.04 TRAINING

- A. Installer shall demonstrate proper operation and maintenance procedures to owner's representative.
- B. Operating keys and owner's manual shall be provided to owner's representative.