

ONYX

WASHROOM CUBICLES

GLASS CUBICLES

Toughened, laminated
back painted glass door cubicles.



SCRATCH RESISTANT



SOLVENT RESISTANT



FOOD GRADE



IMPACT RESISTANT



DURABLE



HEAT RESISTANT



EASY TO CLEAN



QUICK INSTALLATION

STAINLESS STEEL HARDWARES (GRADE 316)

- 1 FLOOR SUPPORT
- 2 COAT HOOK
- 3 HINGES
- 4 DOOR KNOB
- 5 PRIVACY LOCK
- 6 TOPRAIL
- 7 WALL/DIVIDER SUPPORT

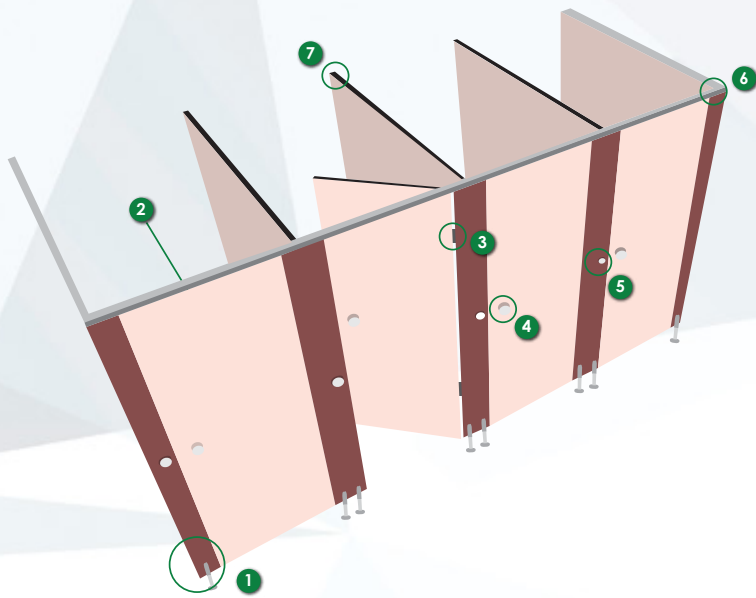

Option:

Post and divider panels: Nominal 25mm thick sandwich panel faced with glass.
Low-Iron Glass, RAL colour match on request.

KEY FEATURES

- Glass Cubicle range - panel doors are painted to any available colours in the Gibca color selector.
- Options of having post and divider panels in painted glass finishes as well.
- Toughened glass cubicles which are extremely durable and hygienic.
- Anti-noise EPDM door buffer.
- Heights of the cubicles can vary fitting the various project requirements.
- Privacy lock options with red/white indicators and provision for emergency access.
- Aluminium profiles are polyester powder coated to match panel color.

SPECIFICATION:

Standard height: 2000mm

Door panels (Nominal): 12.76mm thick laminated back painted glass

Divider: 13mm

Post (nominal): 25mm thick sandwich panel faced with compact laminate

Standard bottom clearance: 100 – 150mm (+/- 10mm)



GIBCA



جیبکا

GIBCA LIMITED COMPANY (FZC) LLC

